

MultiPower

Research infrastructure for DER and other testing activities at VTT is called MultiPower system.

It is a national empirical research environment where new technical solutions and products for distributed energy system can be tested in a multifunctional environment. There are several independent testing facilities connected together so that the environment may cover production, control and loading concepts.

It consists of a laboratory network (400 V, 50 Hz), generating units like 1.6 MVA and 200 kVA diesel generators, 100 kVA micro turbine, 755 kVA converter drive and adjustable loads.

Integrating energy storages and fuel cells is possible, however it has not been implemented at the moment. Multipower has a connection to 20 kV distribution network via a 500 kVA distribution transformer. The laboratory can also be run as an island.



Topics to be tested

The generating units can operate grid-connected or separately loaded. Interesting research topics could be within the following area: synchronization, parallel operation, control systems, protection methods and effect, power and power quality measurements, effects of load sharing and adjustments as well as disconnections of the units or loads.

The influence of low speed and torque variations on the medium size frequency converter can be tested by using a separate motor dynamometer. The characteristics of the drive and responses of the operations can be tested.

The 100 kVA generating units can be connected to 1,6 MVA diesel generator for testing island operation. Interesting research topics could be within the following area: synchronization, parallel operation, control systems, protection methods/effect, power and power quality measurements, effects of load sharing and adjustments is well as disconnections of the units or loads.

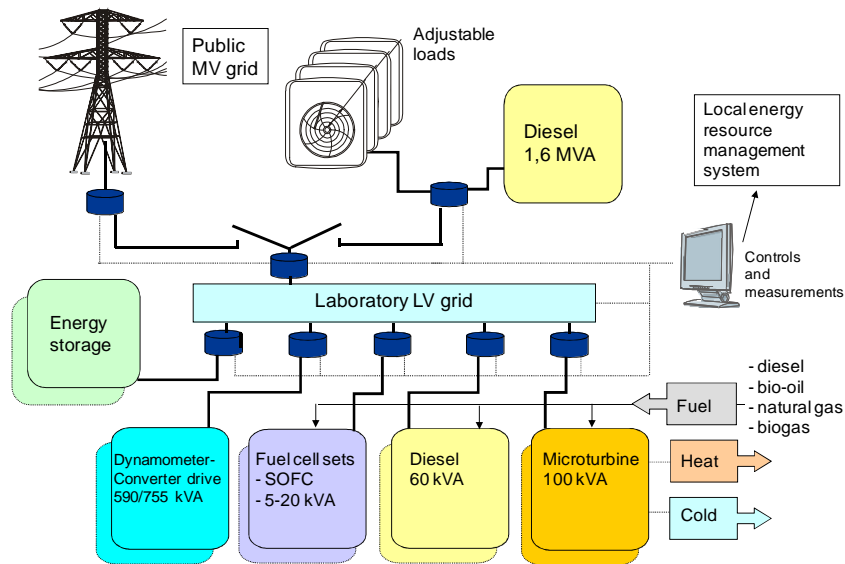

Overview of MultiPower setup.



The 1.6 MVA diesel unit in the laboratory.